

# *Dingo Servo Mounts*

## Twin Servo Control Board MK2

### **Safety Precautions.**

Before installing this product, make sure that you have read the full instruction guide and are comfortable with the requirements.

Make sure that all parts, especially plastic packets, are kept away from young children.

Only use certified power supplies for your region and **DO NOT** interfere with the Mains side of the power supply.

If you are unsure as to how to do the electrical connections, please consult with someone who has the required expertise or contact Dingo Servo Mounts for more information.

These units are not toys, but serious modelling parts.

These boards are still in a test phase of marketing and maybe subject to failure. If this occurs, please contact Dingo Servo Mounts for help.

### **Description and Origin**

The MK2 is exactly the same as the original board except for an improved power supply for the servos and colour coded settings

There are many servo control boards on the market to-day which can be used for model railway point and signal operation.

Most are for multiple servos and offer all sorts of bells and whistles.

There are also a range of excellent kits available to members of the MERG group which offer a variety of control options.

I believe there is a need for a very simple board that offers easy setup and operation for model railway points or semaphore signals.

This is the reason behind the development of this particular board.

The Twin Servo Control Board MK2 has been designed to control 2 servos individually while still using the same firmware as the now well established Single Servo Control Board.

The Twin Servo Control Board is designed for use with standard 9g servos like the TowerPro SG90 Hobby King HK15178 or similar.

The Twin Servo Control Board has a preset slow speed to simulate real life point movement and there is no provision for adjusting the speed. (However they can be supplied with a faster speed on request.)

The two end positions are set very simply by means of a plug in setting box.

A simple single pole on/off switch is all that is required to move the servo from one position to the other.

### **Wiring up.**

You will need a smoothed and regulated DC power supply of 9 – 12 V DC with a capacity of at least 1Amp for a single board.

A standard 2A wall wart will be sufficient to drive quite a few boards as long as not more than 2 are actuated at the same time.

# Dingo Servo Mounts

## Twin Servo Control Board MK2

You will also need two SPST switches to control your board. (This may also be a set of relay contacts or similar from your layout control panel.)

**Note a push button switch will not work unless it is self latching.**

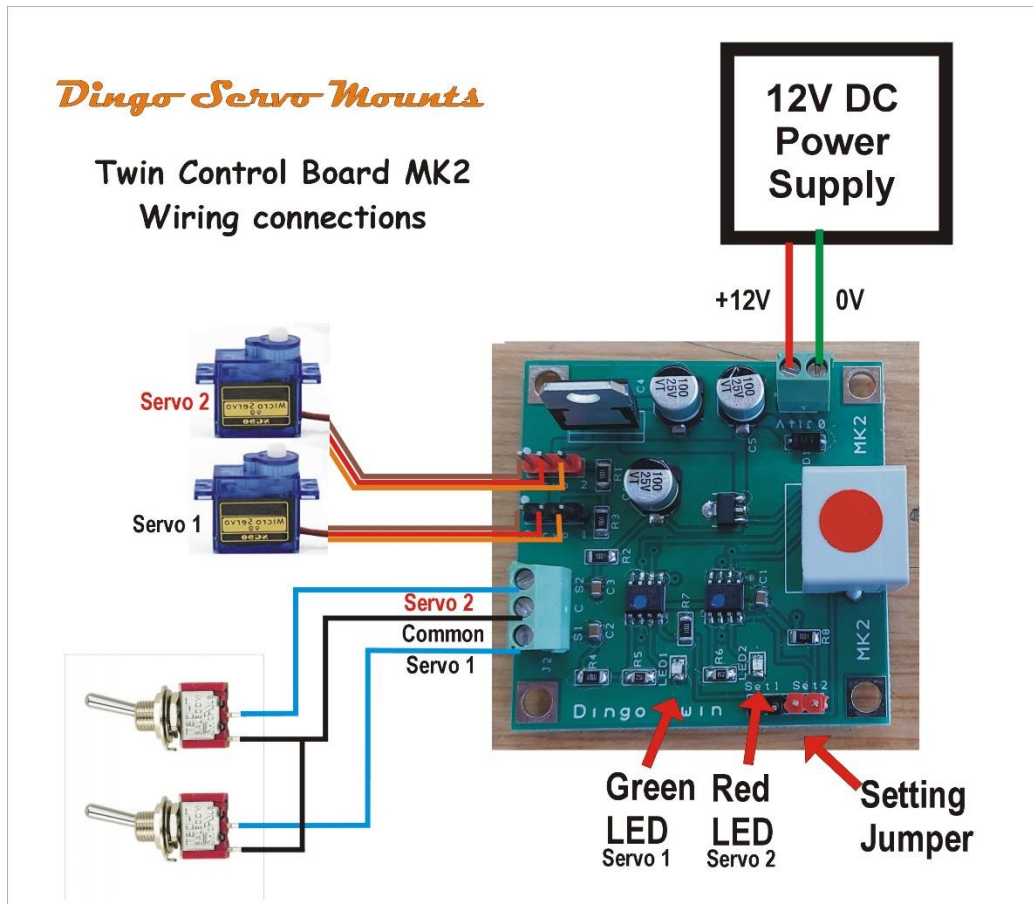

Wire up as per this diagram.

**Note: Servo 1 is the black servo connection, the black setting pins as well as the Green LED.**

**Servo 2 is the Red servo connection, the red setting pins and the Red LED**

Note the polarity of the power supply is important. (If connected the wrong way around, the board will not work but will not be damaged. **(Note this is opposite to the original Board)**)

The servos need to be connected with the black or dark brown lead towards the outside edge of the board. (There is a small white dot on the PCB markings)

The switch simply shorts the two switch contacts together.

Note that the two outside terminals are the two "Live" contacts and the centre one is connected internally to earth. (0v) Both switches need to be connected to this terminal.

In operation Switch (servo1) operates Servo 1 and is connected to the green LED and Switch (servo2) operates Servo 2 and is connected to the red LED.

It is advisable to test the servo and board before fitting the servo to the layout and advisable to use a setting box as outlined in the following section to centre the servo.

# Dingo Servo Mounts

## Twin Servo Control Board MK2

We always recommend using one of our Dingo Servo Mounts to get optimum performance from your servo on your layout.

### Setting up the end positions.

Once the unit is connected as described above, switch on the power and after a second or so the LED's should light to show that the board is in working order.

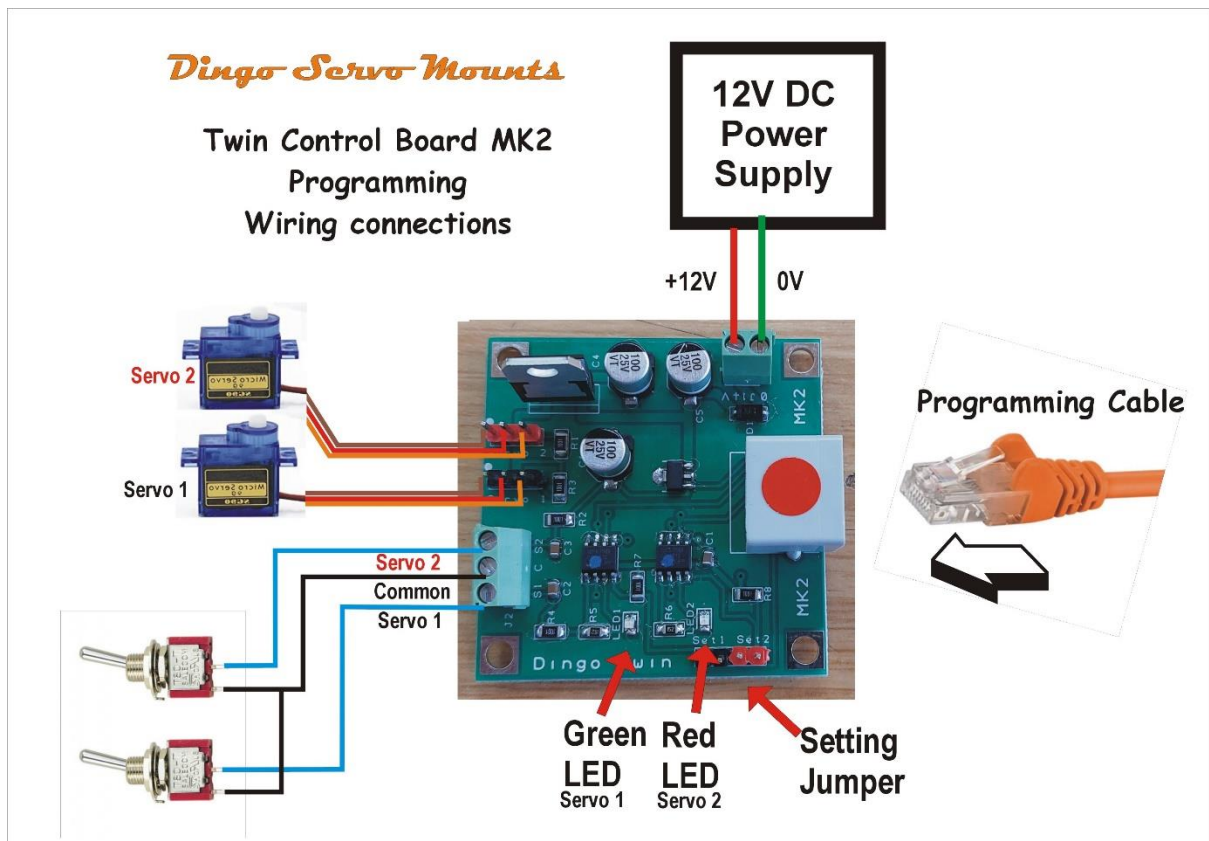

Now plug in setting box into the RJ45 connector on the board.

**Before connecting the setting box make sure that both controls are in the mid position.**

**Arrows or markers pointing straight up.**

### **WARNING!**

#### **Do NOT use Crossover cables**

Use cables supplied by Dingo Servo Mounts or Cat5e straight cables only

**Use of crossover cables can lead to permanent damage**



Now move the setting Jumper to the relevant position to begin setting the end points.

# Dingo Servo Mounts

## Twin Servo Control Board MK2

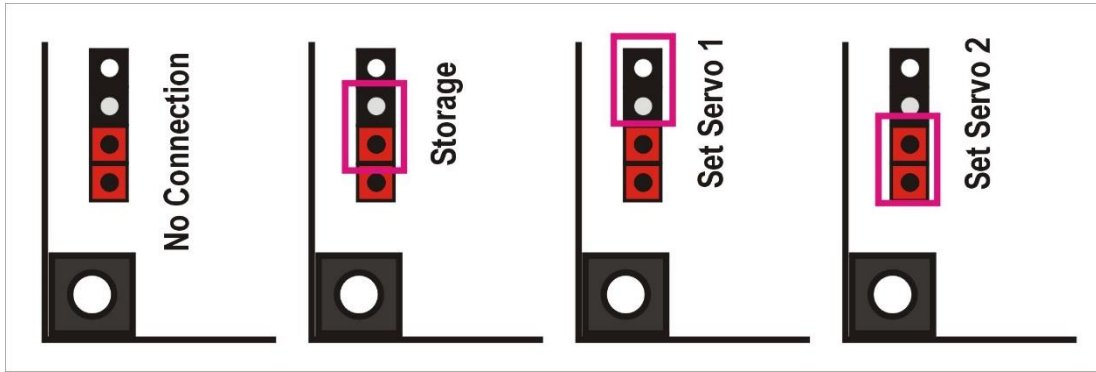

With setting Jumper moved to top position you can set Servo 1 (Black Setting Pins)

Immediately the **Green** LED will start to flash indicating that the board is now in setting mode.

With the switch in the “OPEN” position you can move the servo to the required position using VR1 on the setting box.

Once you have moved the servo into position wait a few seconds until the LED stops flashing – this position is now written to the boards memory.

Now operate the switch to the “CLOSED” position and set the other end by means of VR2 on the setting box.

Again wait until the LED stops flashing and then remove the setting jumper.

The end positions are now set and the unit should operate when the switch is toggled.

If you are not sure which is the open position of the switch you can use which ever control (VR1 Or VR2) moves the servo in the set switch position. Obviously the opposite control will operate in the other switch position.

When you are happy with the setting, move the setting jumper and place it on the lower position in order to set Servo 2 (Red Setting Pins)

The **Red** LED will start flashing and by repeating the method above you can set Servo 2.

When satisfied remove the setting jumper and place in the central position for safe keeping.

It does not need to be on the board for operation, but the centre positions are there just for storage.

Now unplug the setting box and check to make sure that everything is functioning as required.

At anytime the settings can be changed by plugging the setting box in again, setting the required jumper and repeating the above procedure. (Note you don't have to set both units again as they work totally independently.)

**NOTE! The unit will not set if the servo is pushing hard against a stop as the board won't be able to reach the setting point and will thus not set. (LED will continue to flash). Back off slightly until the LED stops flashing before removing the setting box.**

The board is now set and should continue to operate to the same endstops until reprogrammed.

**Please note that all settings are stored in the chip on the board or module so you need to use the board or module that you are using for the particular servo to do the setting up.**

# *Dingo Servo Mounts*

## Twin Servo Control Board MK2

**ONE FINAL NOTE!** Sometimes at switch-on the servos may move to the mid position before going back to the set positions. This is a software protection device to make sure that the servos don't go the wrong way with a bad switch on spike or bad shutdown. It is therefore important that the midpoint of travel is within the 2 set points of the servo.

I hope that you will find this unit useful and as always I welcome any feedback, especially as these boards are still in test production so that I can modify if required to make this a really good servo controller board.

Dave Ingoldby

Mobile 07754901324

[dingoservo@gmail.com](mailto:dingoservo@gmail.com)

[www.dingoservo.co.uk](http://www.dingoservo.co.uk)

If you haven't already seen our amazing servo mounts in action, please check out the Video Links Page on our website.



**Note:** A RED dot on the PCB indicates that the firmware has been updated to be compatible with the Ultra Micro Servos: HK5330 and HK282A as well as operating normal 9g servos. (HK15178, SG90, etc)

Boards without the red dot will not operate the small servos, but will be fine for the normal 9g servos (HK15178, SG90 or similar)

The Red dot also denotes a Point motor control board.

Bouncy Signal boards have a Yellow dot.